



RELATIVE PRESSURE TRANSMITTER – INSTRUCTIONS MANUAL – V1.0x E

INTRODUCTION

The T83/84 positive relative pressure transmitters are robust and reliable equipment suitable for general industrial applications. They are available in several measuring ranges and process connection threads.

PRECAUTION

Before operating the transmitter, carefully read its specifications and operating instructions. In case of damage caused by incorrect operation or inappropriate usage, and its consequences, warranty becomes ineffective and null.

A specialized professional shall perform the installation.

A specific electrical power supply network should be provided for instruments use only.

UNPACKING

After unpacking the product, besides the transmitter it must be available:

- A quick guide to installation and operation.
- A sealed electrical connector.
- A screw to fix the connector to the transmitter.

IDENTIFICATION

An identification label is attached to the equipment housing. On this label, you can found detailed information about the transmitter.

Fig. 1 shows the identification label.

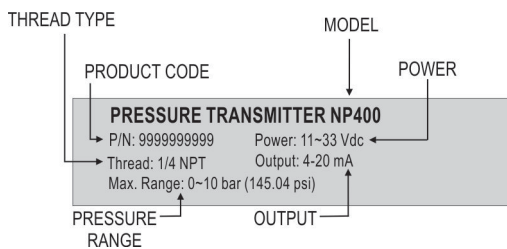

Fig. 1 – Transmitter identification

SPECIFICATIONS

Type of Measure:

Positive relative pressure

Pressure Range:

- 0.2 MPa (2 bar / 29.01 psi)
- 0.5 MPa (5 bar / 72.52 psi)
- 1 MPa (10 bar / 145.04 psi)
- 1.6 MPa (16 bar/ 232.06 psi)
- 2 MPa (20 bar / 290.08 psi)
- 2.5 MPa (25 bar / 362.59 psi)
- 4 MPa (40 bar / 580.15 psi)
- 5 MPa (50 bar / 725.19 psi)
- 6 MPa (60 bar / 870.20 psi)
- 10 MPa (100 bar / 1450.38 psi)
- 16 MPa (160 bar / 2320.60 psi)
- 25 MPa (250 bar / 3625.94 psi)
- 40 MPa (400 bar / 5801.51 psi)

Measurement Accuracy:

NP400 (≤ 50 bar) < ± 0.5 % Max. Range

NP400 (100 bar) < ± 1.0 % Max. Range

Including linearity, hysteresis and repeatability, in 25 °C

Thermal Deviation Maximum:

< ± 0.06 % the span / °C

Overpressure Range:

Twice the Max. Range.

Rupture Pressure:

Three times the pressure range upper value.

Output Signal (Output):

Electric current, 4-20 mA, 2 wires.

Power Supply (Power):

11 to 33 Vdc

Maximum Load (RL):

$RL = (Vdc - 10) / 20 \text{ mA } (\Omega)$

Where: Vdc= Power supply voltage

Electrical Connection:

Connector for Type A valves (DIN EN 175301-803), IP65.

Conductor 1.5 mm² (max.) and cables between 6 and 8 mm in diameter.

Operating Temperature:

-20 to 70 °C

Medium Temperature:

-20 to 100 °C

Dynamic Response:

< 30 ms

Process Connection (Thread):

¼ NPT; ½ NPT; ½ BSP; G ¼ (*)

Sensor features:Piezoresistive – Thick Film on Ceramics (Al₂O₃ 96 %)**Metal housing of the transmitter:**

Stainless 316

Wetted parts:Sensor Ceramic, Al₂O₃ 96 %

Sealing Ring, FKM

Metal Connection, stainless steel 316

Compatibility: Any gas or liquid compatible with the constituent materials of the wetted parts.**Certification:** CE

(*) Information available on the product identification label.

Note: For models with process connection ½ BSP and G ¼, the outer seals are manufactured with FKM.

THREAD	A (mm)	B (mm)	WEIGHT (g)
NPT ¼	15.5	51.0	106
NPT ½	20.0	56.5	159
BSP ½	14.0	49.5	121
G ¼	14.0	49.5	105

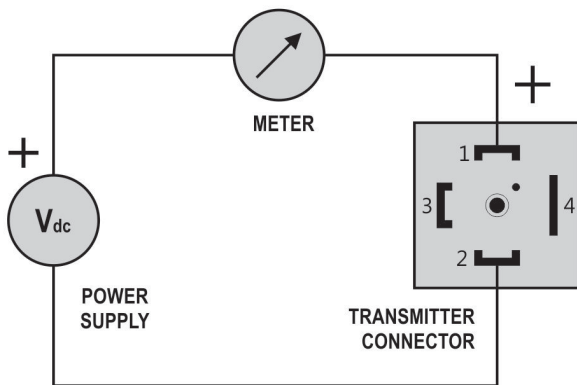
Table 1 – Transmitter thread type, dimensions and weight**ELECTRICAL CONNECTIONS****Fig. 2** – Electrical connections**Installation recommendations**

- The instruments must be powered from a dedicated instrumentation power supply.
- It is strongly recommended to apply RC'S FILTERS (noise suppressor) to contactor coils, solenoids, etc.
- To improve measurement stability, immunity and safety, it is recommended to use system grounding.

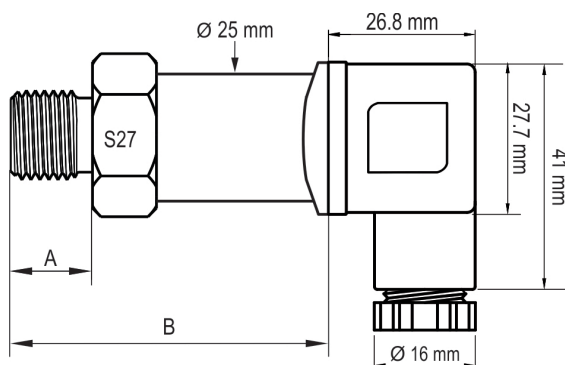
DIMENSIONS**Fig. 3** – Transmitter dimensions

NOTE: Previous versions (2020) have other measurements.